

SH-TP-B Drilling Template  
 print on 11x17 (do not scale)

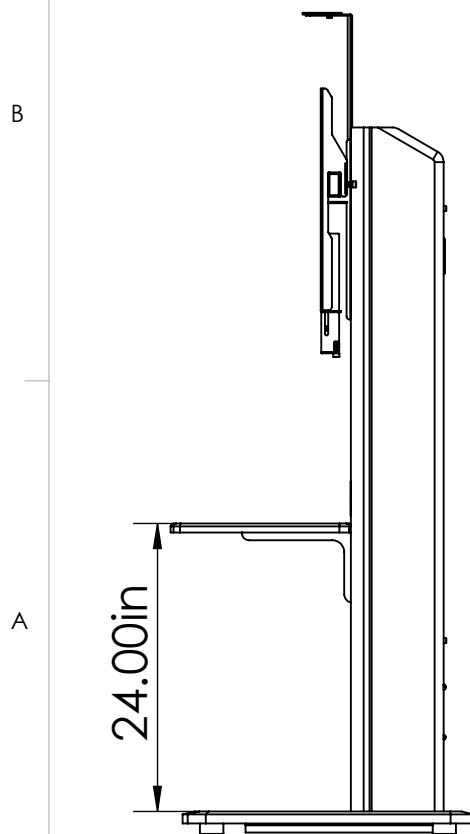

1. Remove back off TP800/1000 stand using Allen key (m6 bolts)
2. Drill out partially drilled Grommet hole using router bit or rotozip.
3. Place template 24" from bottom of extrusion to top of shelf. level and tape in place.
4. Drill through template using a 3/16 or 1/4" Drill.
5. Insert 60mm Grommet included
6. Attach shelf brackets using 3/16x1.25 bolts,washers and nuts x4
7. Attach shelf using 3/4" wood screws provided.
8. place plastic covers over metal brackets.

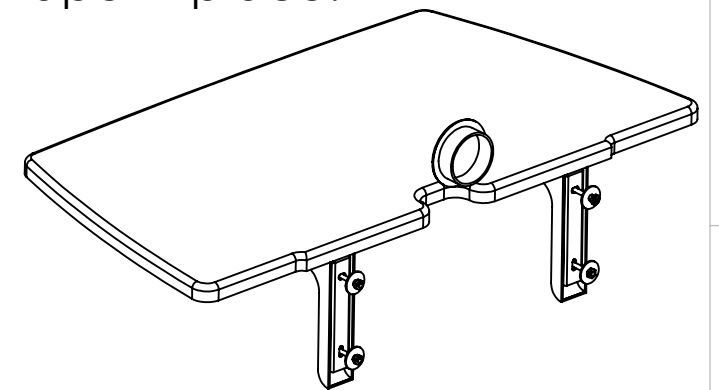

**Included Parts.**

- 1x SH-TP-B shelf
- 2x Metal L bracket w plastic covers
- 1x SH-TP-B hardware bag
- 1x 2 3/8 (60mm) Grommet

<b>ELECTRONIC COPY IS MASTER. DO NOT USE UNLESS STAMPED AND APPROVED</b>			APPLICATION	
DRAWN	NAME	DATE: YMD	TITLE:	
CHECKED	M.Fischer		SH-TP-B	REV
DESIGNED	M.Fischer			00
<b>PROPRIETARY AND CONFIDENTIAL</b>			DWG. NO.	
<small>THE INFORMATION CONTAINED IN THIS DRAWING IS THE SOLE PROPERTY OF AVFI. ANY REPRODUCTION IN PART OR AS A WHOLE WITHOUT THE WRITTEN PERMISSION OF AVFI IS PROHIBITED.</small>			SH-TP-B	
SCALE: 1:1		SIZE <b>B</b>	SHEET:1 OF 1	