



# VIDEO FURNITURE INTERNATIONAL

Furniture Designs That Communicate

## Package O PM-XFL-LIFT + TVCB-XL



Shown with SMART Board® 8070i interactive display

### Package O



+

Your  
Electronics

+



### Package O PM-XFL-LIFT + TVCB-XL

Package O comprised of the PM-XFL-LIFT (Mobile Electric Lift) and the TVCB-XL (TV mounted camera bracket) are the ideal combination when mobility and electric lifting capability are mandated. This pair perfectly lends itself to most educational teaching, business, military, courtroom and corporate training environments.

The PM-XFL-LIFT heavy duty floor mount for single monitors has motorized lift capability for up to 80" flatscreen or \*\*SMART Board® interactive displays\*\* (Landscape orientation) weighing up to 265 lbs or 120kg and it is a self supporting and wheeled stand. Ideal for environments where adjustable height or ADA is required. TVCB features adjustable camera height for different size TV's.

#### Standard Features Include:

##### PM-XFL-LIFT

- Accommodates up to 80" flatscreen (265 lbs max)
- Accommodates \*\*SMART Board® interactive displays \*\*\*6052i and 8070i
- 20" travel electric Worm-Drive actuator for safety and reliability
- Cable pushbutton remote for easy incremental adjustments
- 325lb capacity metal 5" casters with ballbearings, non-marking wheels, 2 are locking
- Wiring channel inside main pillar
- Sturdy 11 GA steel construction
- Base is heavy duty steel tube construction

##### TVCB-XL Camera Bracket

- Accommodates most 52" - 70" flat panel monitors
- Sturdy 11ga steel, powder coated texture black
- Fits most cameras including wide HD cams (Eagle Eye)
- Camera height adjustable for different TV sizes
- Fastening hardware included

#### Options

##### PM-XFL-LIFT

- **PM-PB** Mounted six outlet power bar with 10 ft. cord
- **PM-2RU** 2RU bracket
- **CBB-TV** Camera bracket (26" - 70" TV's)
- **BKT-C20** C20 Codec bracket
- **FEET** Adjustable height feet for non-mobile installs

##### TVCB-XL Camera Bracket

- **PB** Six outlet power bar with 10 ft. cord

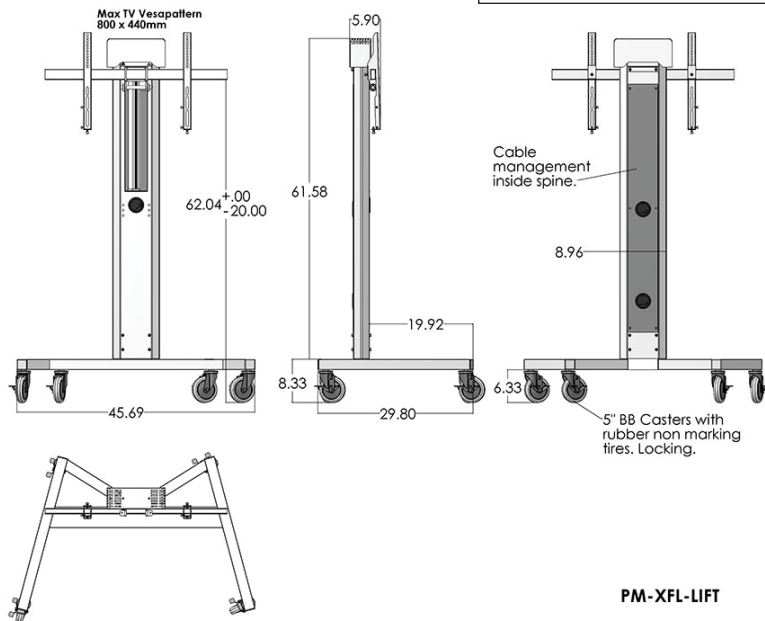

#### Specifications:

BLACK

PACKAGE	WIDTH	DEPTH	HEIGHT
O	46" or TV	29 1/2"	65" min.

\*\* SMART Board® is a trademark or registered trademark of SMART Technologies ULC in the U.S. and/or other countries

\*\*\* Not verified by SMART. Interactive displays are different than interactive whiteboards

VFI can build or modify stock configurations to suit customer specifications. Please contact us to discuss how this service can help meet your needs. Some quantity restrictions may apply.

\* Specification subject to change without notice

\* Computers, cameras, monitors, etc. are shown to illustrate product usage and are not included unless otherwise noted.

190 Don Hillock Drive . Aurora . Ontario . L4G 0G9

Tel: (905) 751-1459 Toll Free: (877) 834-3876 Fax: (905) 751-1488

✉ sales@video-furn.com 🌐 www.video-furn.com