

Thank you for purchasing VFI's universal display mounting system. These products are designed for tabletop mounting of a single or dual plasma/lcd TV's sized 32-50+" and weighing no more than 160lbs each. Some larger TV's will fit, Download TV manufacturers specs online, max hole location is 700mm wide x 440mm high

Note: 2 persons are required to attach plasma/lcd TV's to this mount.
If you cannot understand these instructions or are concerned about safety of the installation Contact a qualified contractor or contact VFI at 1-877-834-3876.

Confirm all parts are included before you begin assembly.
Not all hardware supplied will be used depending on the manufacturer of your display/s.
Read these intructions start to finish before beginning installation.

Supplied Parts:

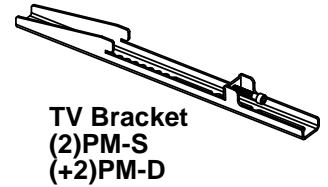
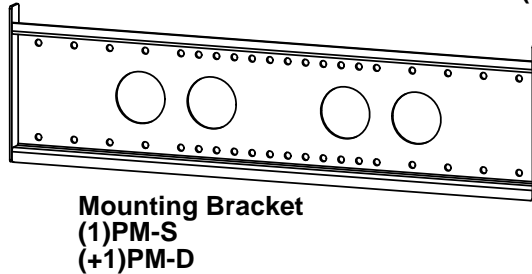
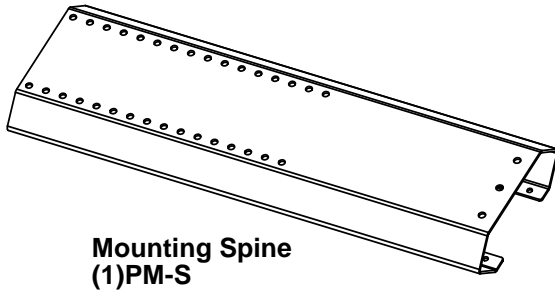
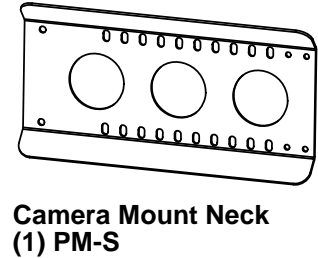
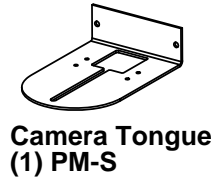
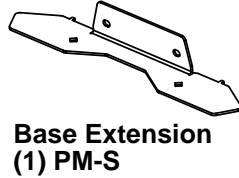
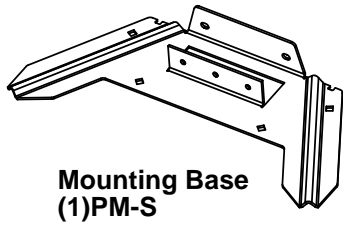

Note: You will need the PM-S box in addition to the PM-D box to assemble a PM-D.
(+)Items only come in the PM-D box.

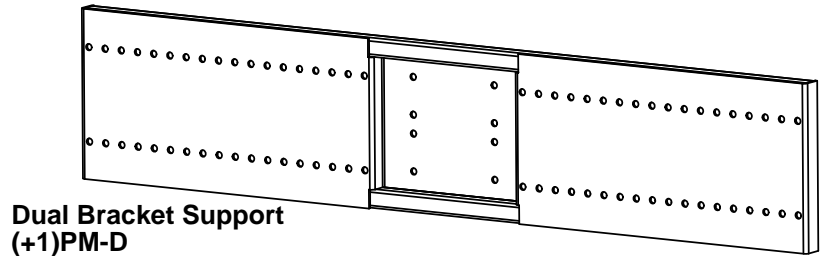

Supplied Hardware: (1) in PM-S Bag , (+1) in PM-D Bag

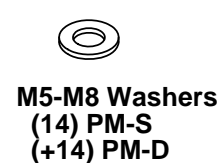
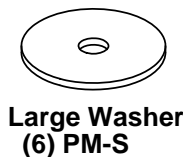
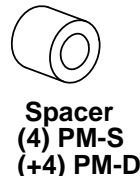
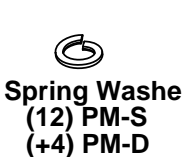
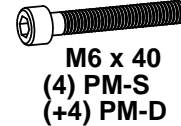
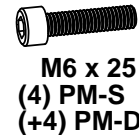
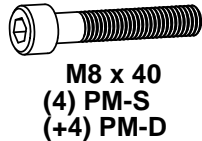

Tools required:
(not supplied)

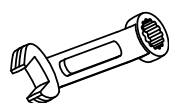

Wrench or Socket (2)
9/16inch
13mm

Tape Measure



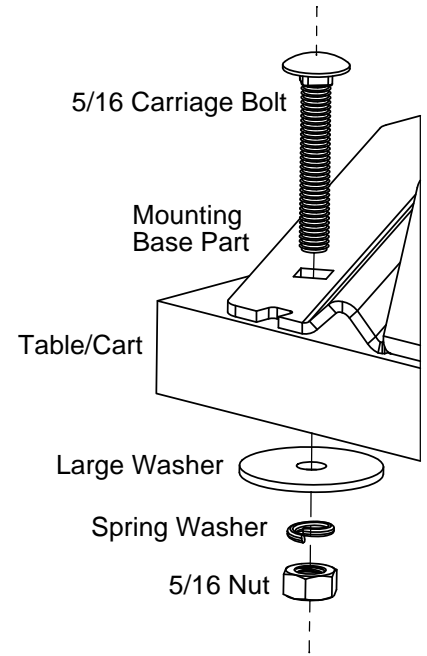
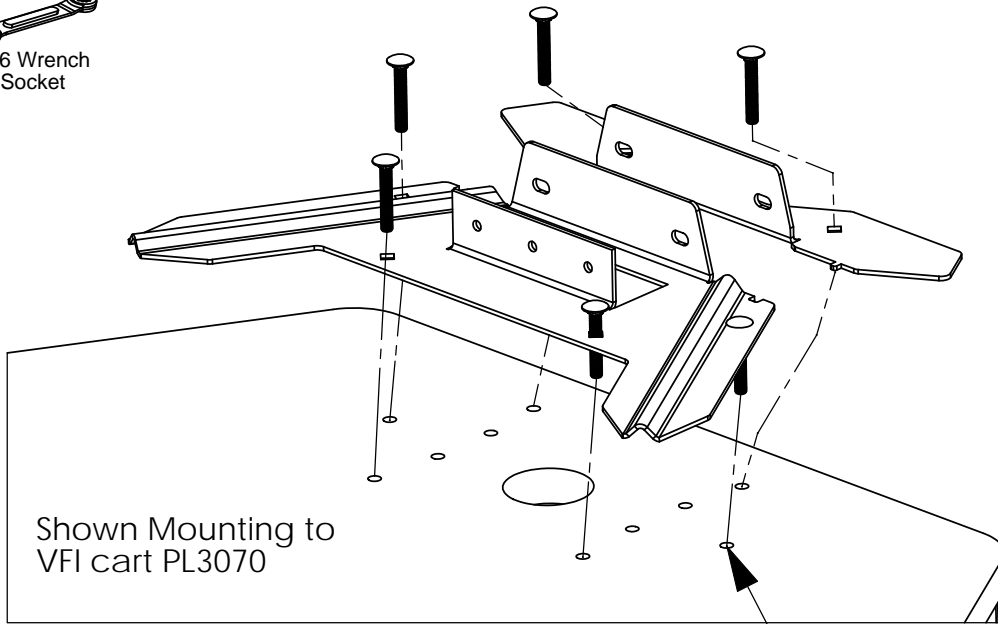

Tighten all 6 nuts securely



If your cart/table does not have pre-drilled holes.
See Page 8 for optimal placement of base.
Remove grommet if present, surface must be flat.

Step 2 Adding the Mounting Spine

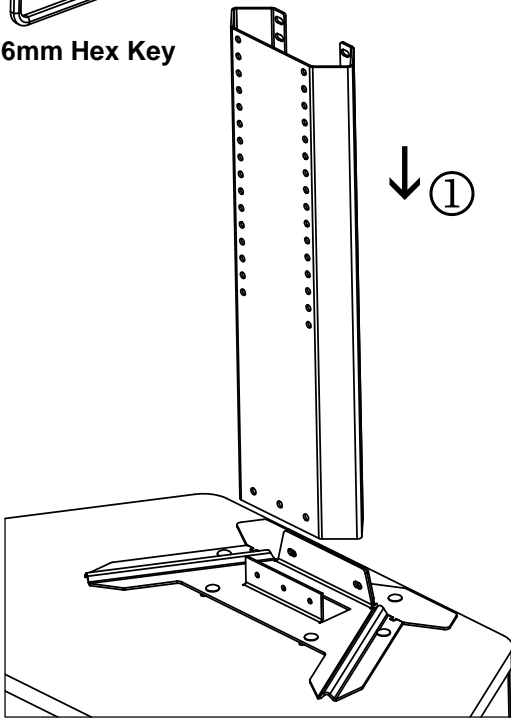

1. Insert Mounting Spine into Base as shown
2. Add the back bolts first. Do not tighten till front and back bolts are in place.
3. Use your 6mm hex key to tighten all 5 bolts

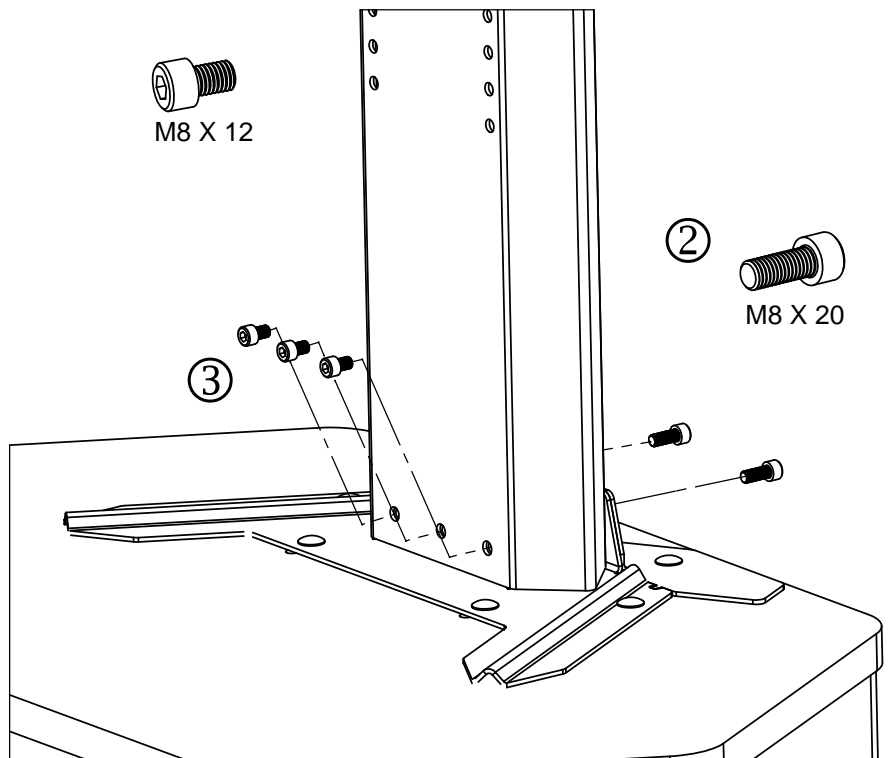

Note: Optional Base shroud can be inserted over-top at the end of Step 2. see bottom of page 8 for description.

VIDEO FURNITURE INTERNATIONAL

190 Don Hillock Drive, Aurora, Ontario L4G 0G9 www.video-furn.com
Toll Free: 1-877-834-3876 Fax: 1-905-751-1488 Local: 905-751-1459



1. Place TV face down on blanket or non abrasive surface such as cardboard.
2. Check to see if your TV came with mounting hardware or not. If not, we have supplied the most common hardware. Most displays under 42" will use the M6 bolt. Most 42"+ will use the M8 bolts. See which bolt length you need by hand tightening only.
3. Place TV brackets so you can see the TV mounting holes through the bracket and insert bolt through appropriate washer and spring washer.
4. Use the Hex key to tighten until there is resistance, then give a half turn.
DO NOT OVERTIGHTEN AS THIS CAN DAMAGE OR PUNCTURE THE TV

Note. Have 2 people lift the TV as it can be very heavy and awkward. Some TV's require non standard hardware. This bracket was made to accomodate up to M10 bolts which can be found at your local hardware store along with longer versions of the included hardware.

Optional Spacer mounting

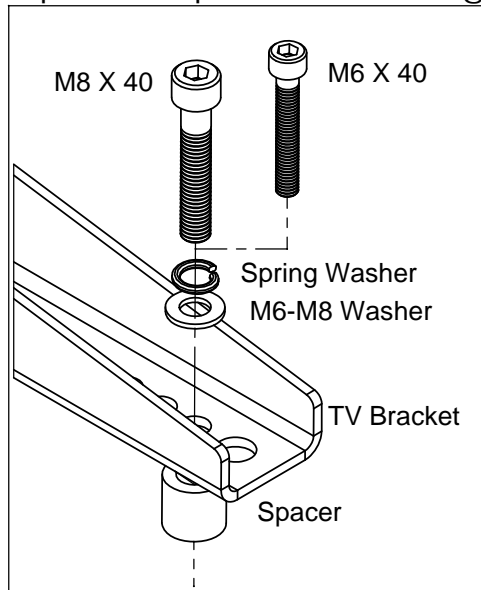

Spacer is used when the back of TV is not flat or the mount holes are sunk into the back of the TV. (Rarely used)

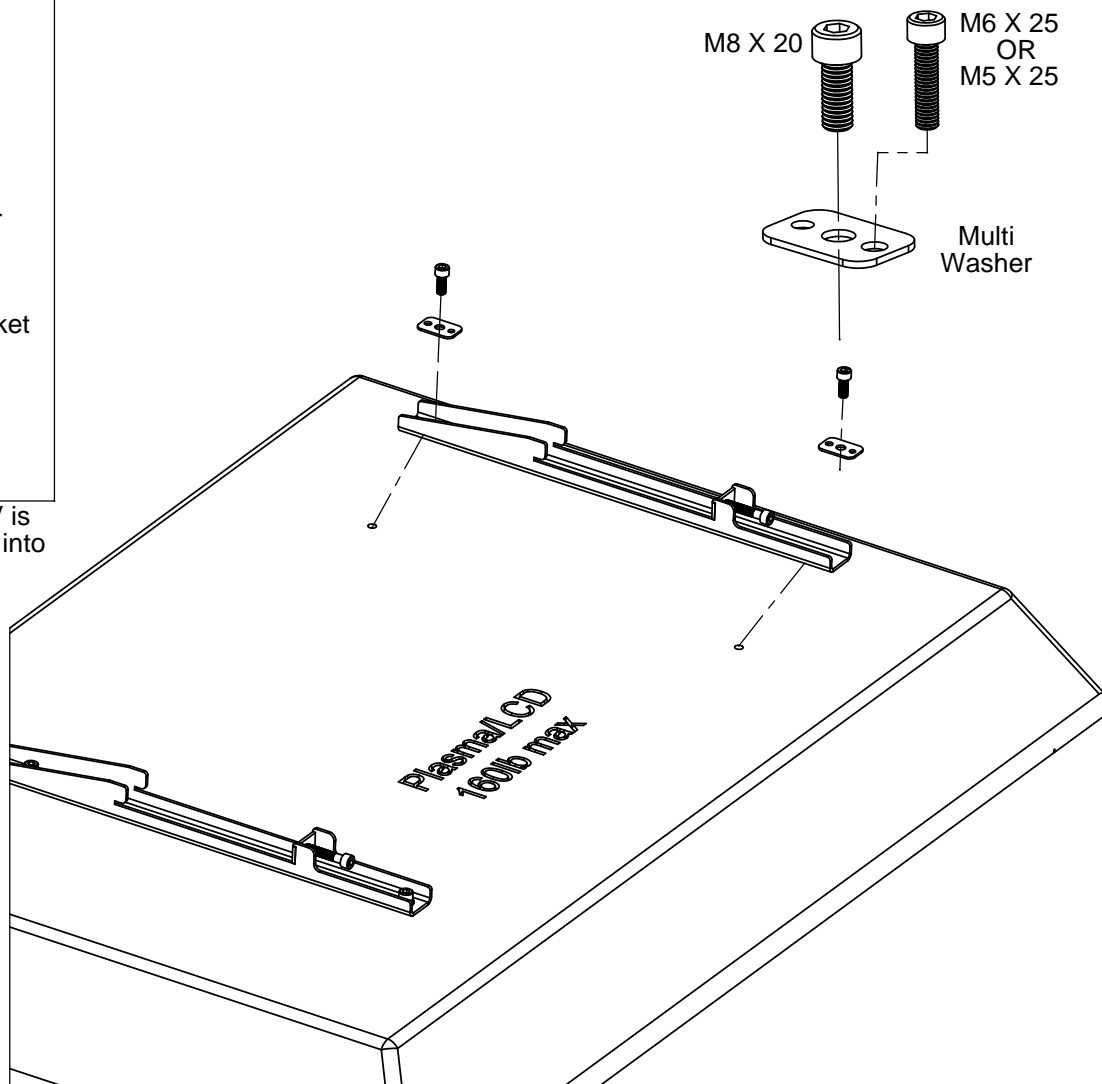

Step 4-D Dual Bracket Support (PM-D only) (PM-S go to Next Page)

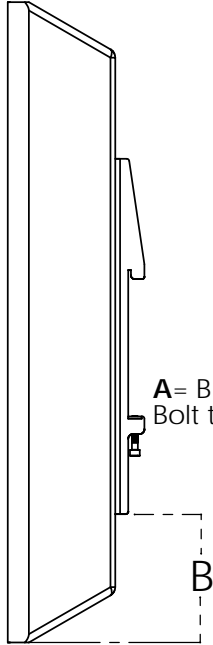

$A = B + 4"$
Bolt to the nearest upper hole.

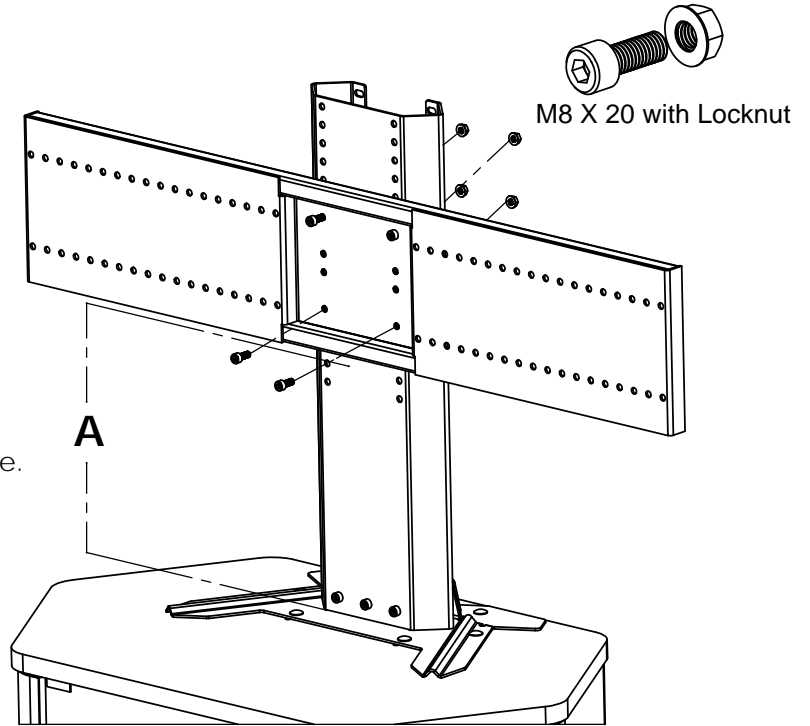

Step 4.5-D Locating and Installing Mounting brackets

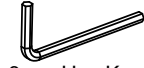

$C = (D - 29.5")$ divided by 2
Bolt to the nearest outward hole.
Some tolerance will remain for adjusting.

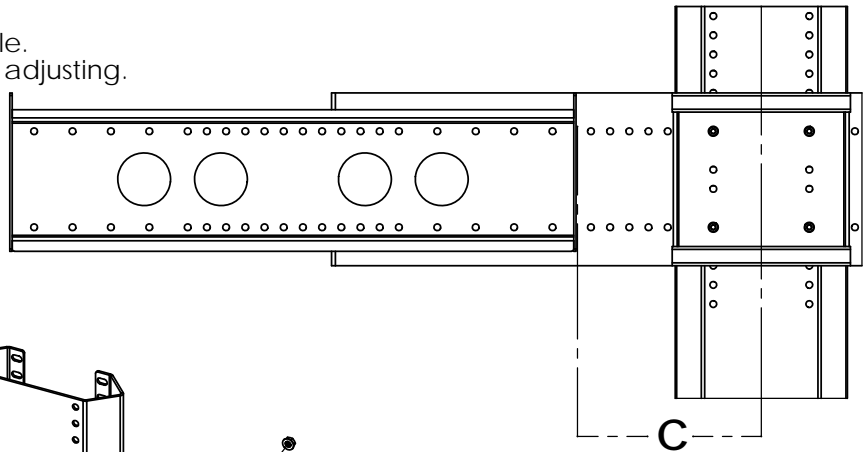
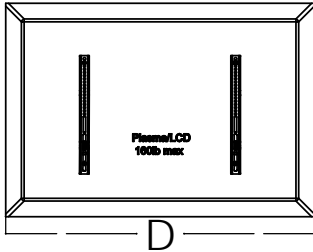

Note: You will need the PM-D hardware bag in addition to the PM-S hardware bag to complete this step.

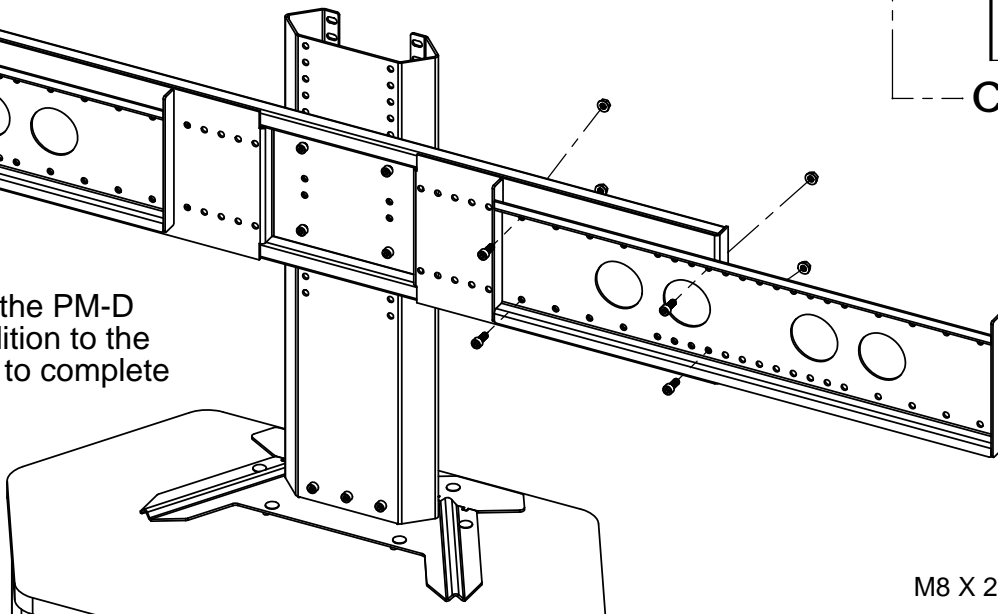

Lock Nut
M8 X 20

VIDEO FURNITURE INTERNATIONAL

190 Don Hillock Drive, Aurora, Ontario L4G 0G9 www.video-furn.com
Toll Free: 1-877-834-3876 Fax: 1-905-751-1488 Local: 905-751-1459



6mm Hex key

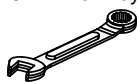

13mm Wrench or Socket



1. Figure out the location of the bracket.
A = B + 4" (see below where to measure B distance)
Bolt to the nearest upper hole.

2. Make sure to center the bracket.

3. Tighten all 4 bolts.

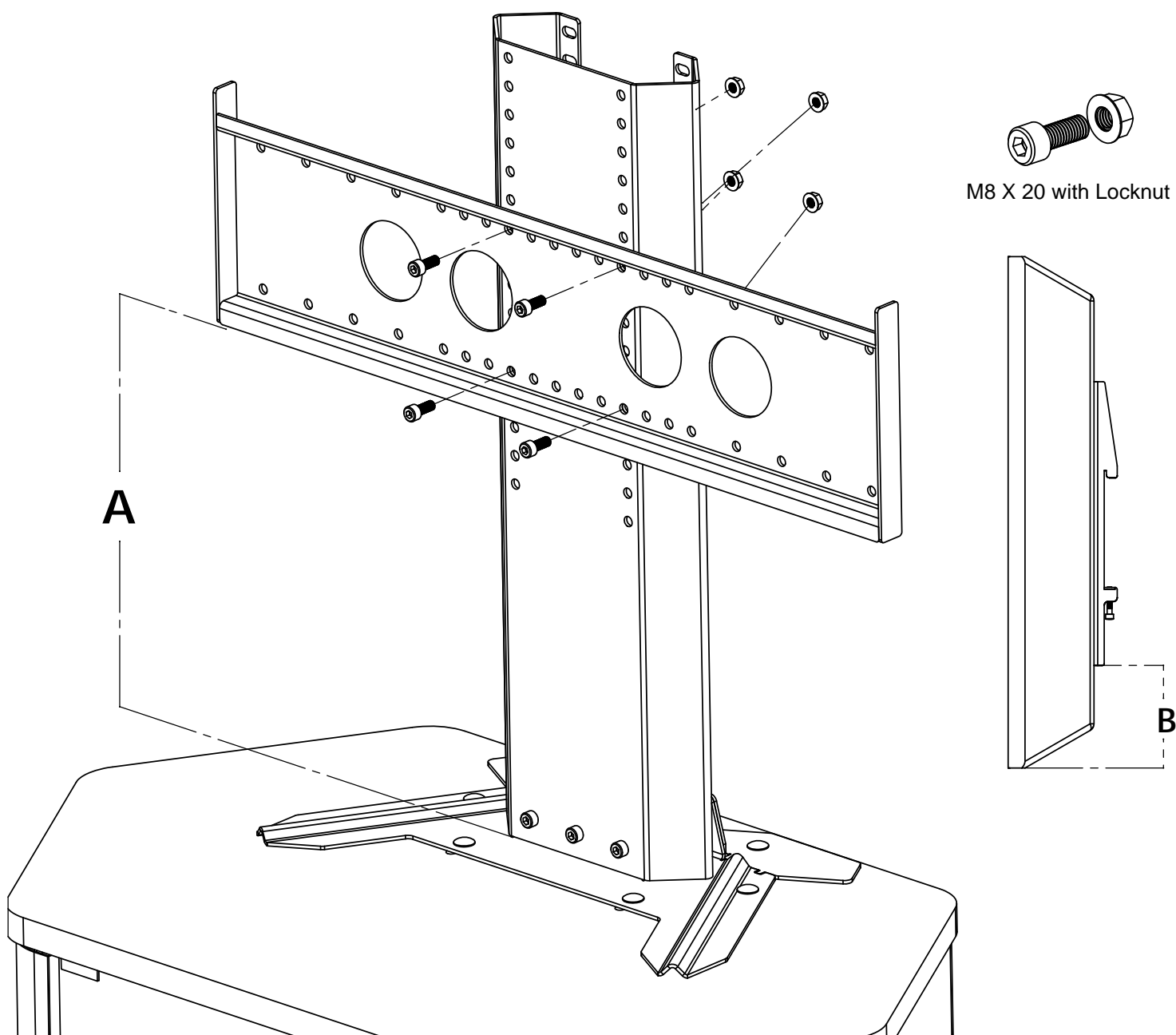



6mm Hex key

⚠ ⚠ Note: 2 people should lift and secure the TV as it can be heavy and awkward.

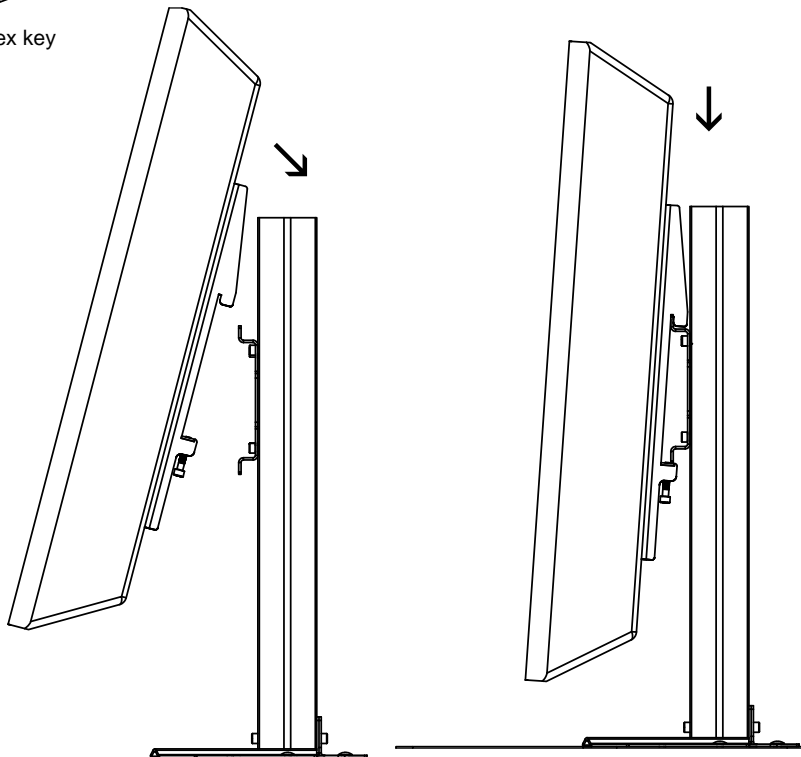

① Hang the TV, First hooking the top of the Mounting Bracket rail then allowing the TV to rest on the rail.

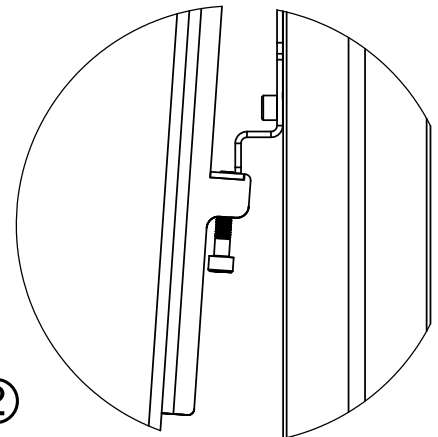

②

Make sure Bolt clears bracket, TV will tilt until its flush with the mount, Tighten bolt until it catches on the bracket.

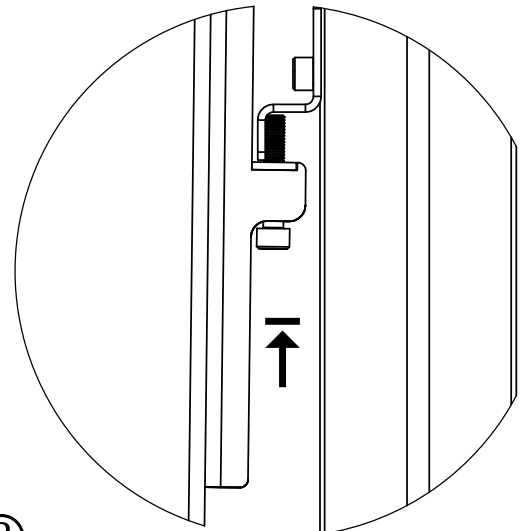

③

Once your TV is centered. Completely tighten bolt against metal bracket.

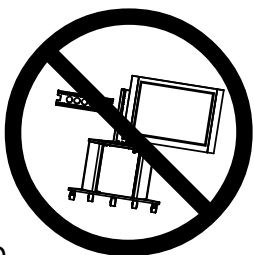

PM-D
Never leave one TV attached.
Always have someone support the attached TV as the other side is hung. This may require 3 people.

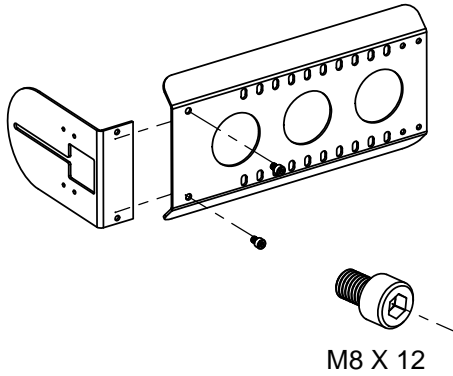

1. Bolt tongue to camera mount neck
2. Insert mount neck into mounting spine until tongue is approximately 1-2" from the top of the TV.
3. Bolt camera mount neck into mounting spine. Tongue is now ready for camera.

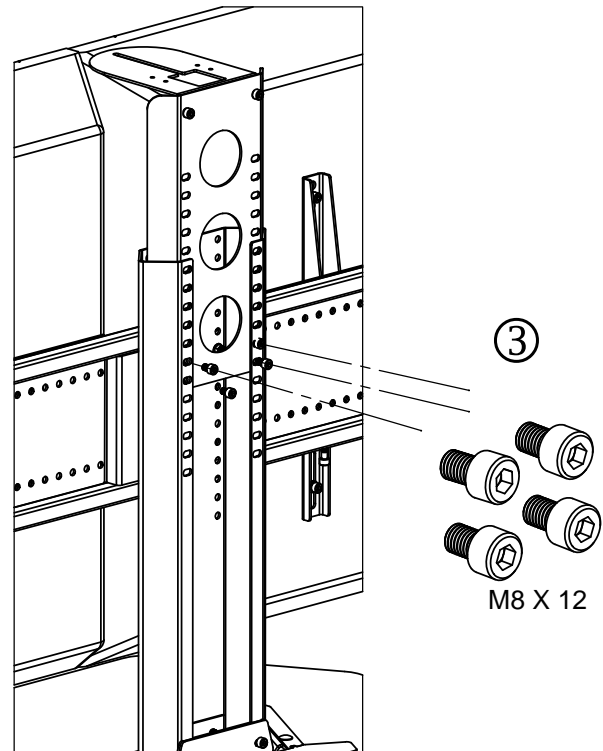
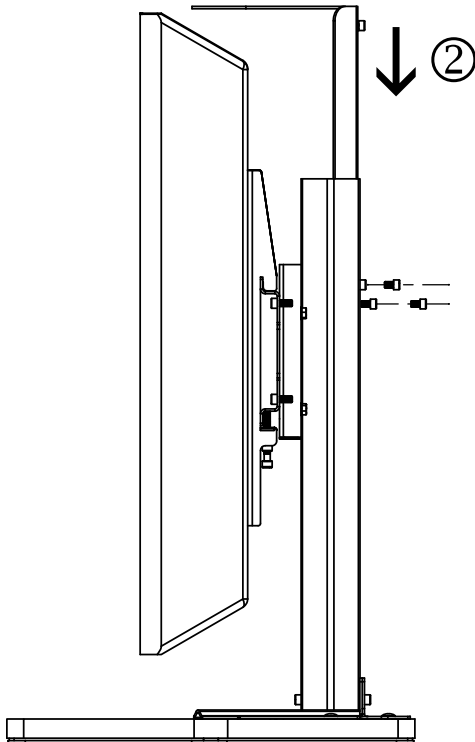

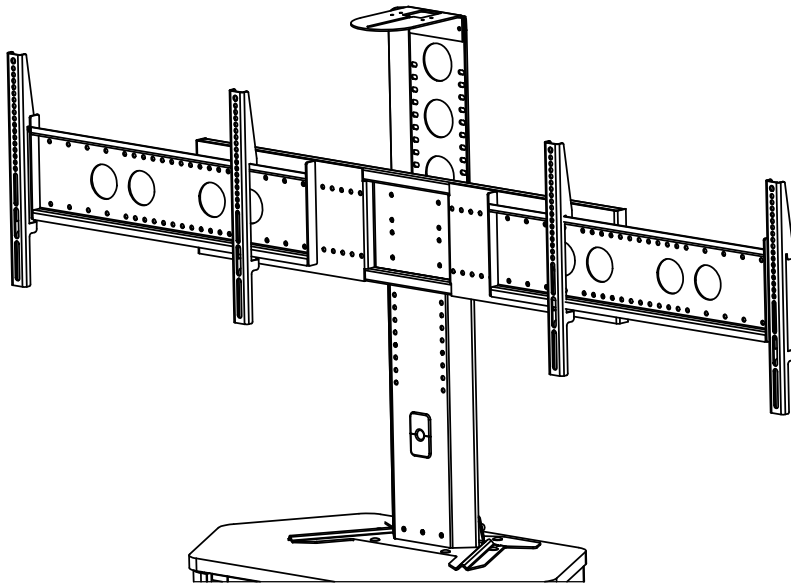

TV's hidden for mount visibility.

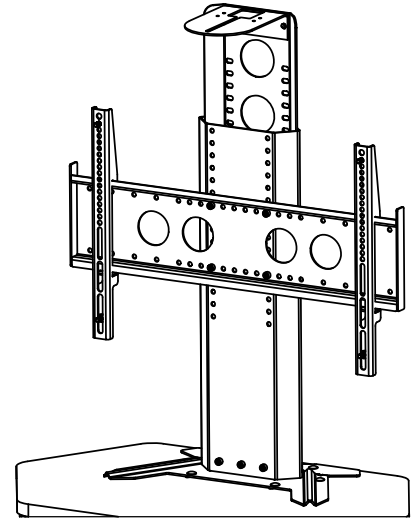

PM-D

PM-S

Congratulations! you're done.

You will notice you have a bit of hardware left over which you may need in the future.

We suggest placing this in a small bag and taping it inside the bottom back of the spine.

(A PM-S can be upgraded to a PM-D by ordering a PM-D expansion box)

If you have any problems, questions or suggestions, we value your feedback. Toll free 1-877-834-3876

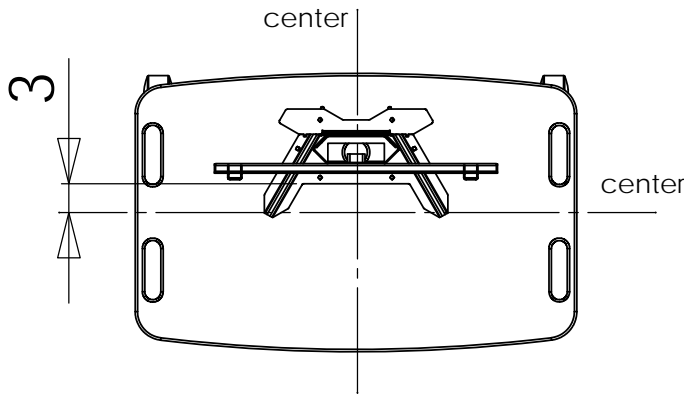

Optimal placement of base.

If your cart did not have pre-drilled holes and you need to locate the mount:
 Remove grommet if present, surface must be flat.
 Place base 3" back from center.
 Mark hole center locations with punch or pencil
 Drill through with an 3/8 drill.
 Place base and insert all 6 Carriage bolts to confirm holes.

Optional accessories

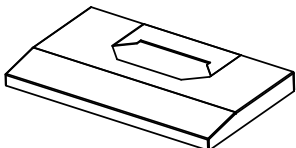

PM-CVR
Base cover (2 pc)

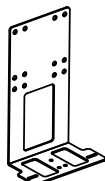

PM-HDCB
High Def Codec Bracket

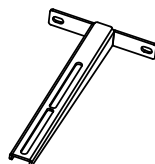

PM-CAM (PM-D only)
eye level cam mount



PM-CMP
Codec mounting plate

See www.video-furn.com for latest optional accessories.

VIDEO FURNITURE INTERNATIONAL

190 Don Hillock Drive, Aurora, Ontario L4G 0G9 www.video-furn.com
 Toll Free: 1-877-834-3876 Fax: 1-905-751-1488 Local: 905-751-1459