



# VIDEO FURNITURE INTERNATIONAL

Furniture Designs That Communicate.

103420, Multimedia Furniture



## Model 103420 Multimedia Stand

VFI's multimedia stand is an excellent choice in a roll-about cart for your smaller peripherals. This multi-purpose cart is ideal for items such as computer monitors, LCD projectors, overhead projectors, and laptops. It's flip up shelf is ideal when you need extra space for your laptop or presentation notes. The unit is equipped with multiple cable management ports as well as a rear access door. The cart's interior is engineered to allow easy installation of the optional 10 space rack rail kit. This cart is shipped fully assembled to save your staff time during installation. Available in black "Fortress" finish.

### Options

- PB Six outlet power bar with 10ft cord.
- MM1232 12"-32" LCD Monitor/TV mount
- RU 10 space rack rail kit.
- 6" Soft wheels.
- Exhaust fan

### Standard Features Include:

- "Fortress" scratch resistant paint.
- Included Flip up shelf, can be moved to either side.
- Rear door for easy access to equipment stored inside.
- Premium casters for easy maneuvering.
- Adjustable interior shelf.
- Four rear panel cable access ports.
- Tinted tempered glass door.
- Ships fully assembled.
- Permanent construction process.

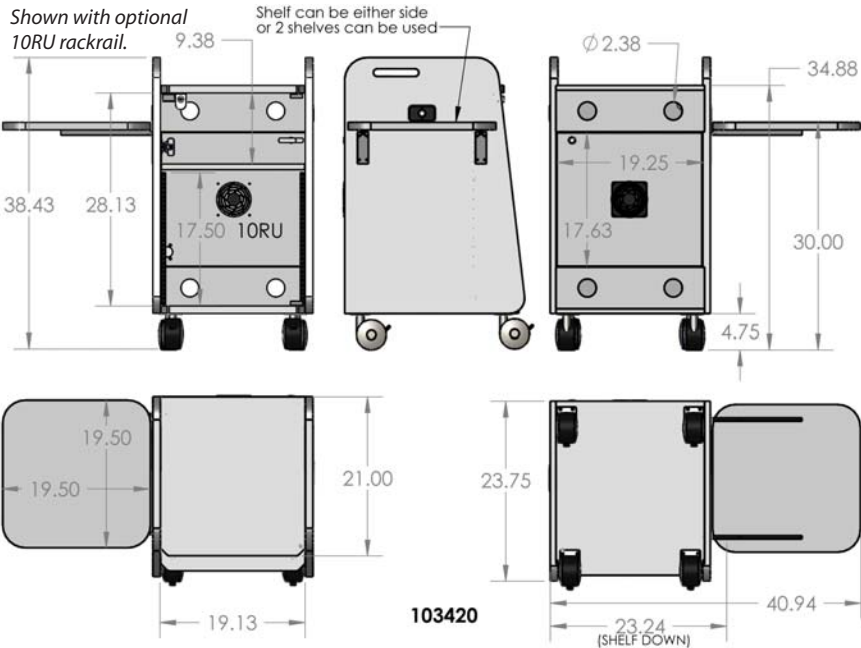

\* Ask your reseller about adding microphones, lights and other add-on options.

### Specifications:

BLACK

MODEL	WIDTH	DEPTH	HEIGHT
103420	21"	24"	38"

VFI can build or modify stock configurations to suit customer specifications. Please contact us to discuss how this service can help meet your needs. Some quantity restrictions may apply.

\* Specification subject to change without notice.

\* Computers, cameras, monitors, etc. are shown to illustrate product usage and are not included unless otherwise noted.

190 Don Hillock Drive . Aurora . Ontario . L4G 0G9

Tel: (905) 751-1459 Toll Free: (877) 834-3876 Fax: (905) 751-1488

sales@video-furn.com

www.video-furn.com